

PARTS CATALOG

Series SLZ Ceiling Cassettes R410A

Indoor unit
[Model names]

SLZ-KA09NA

SLZ-KA12NA

SLZ-KA15NA

[Service Ref.]

SLZ-KA09NA.TH

SLZ-KA12NA.TH

SLZ-KA15NA.TH

Note:

- RoHS compliant products have <G> mark on the spec name plate.
- For servicing RoHS compliant products, refer to the RoHS Parts List.

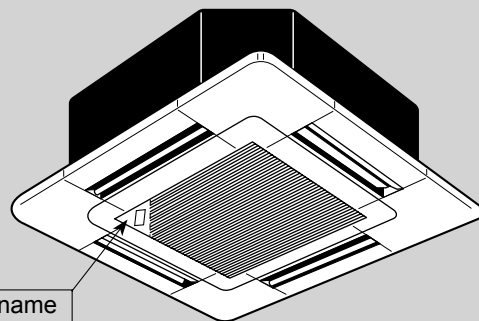

INDOOR UNIT

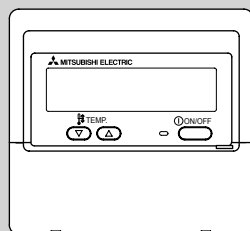

REMOTE CONTROLLER
(Option)

CONTENTS

1. RoHS PARTS LIST..... 2

SERVICE MANUAL (OCH487)



Mr. SLIM™

PANEL PARTS
SLP-15AAUW

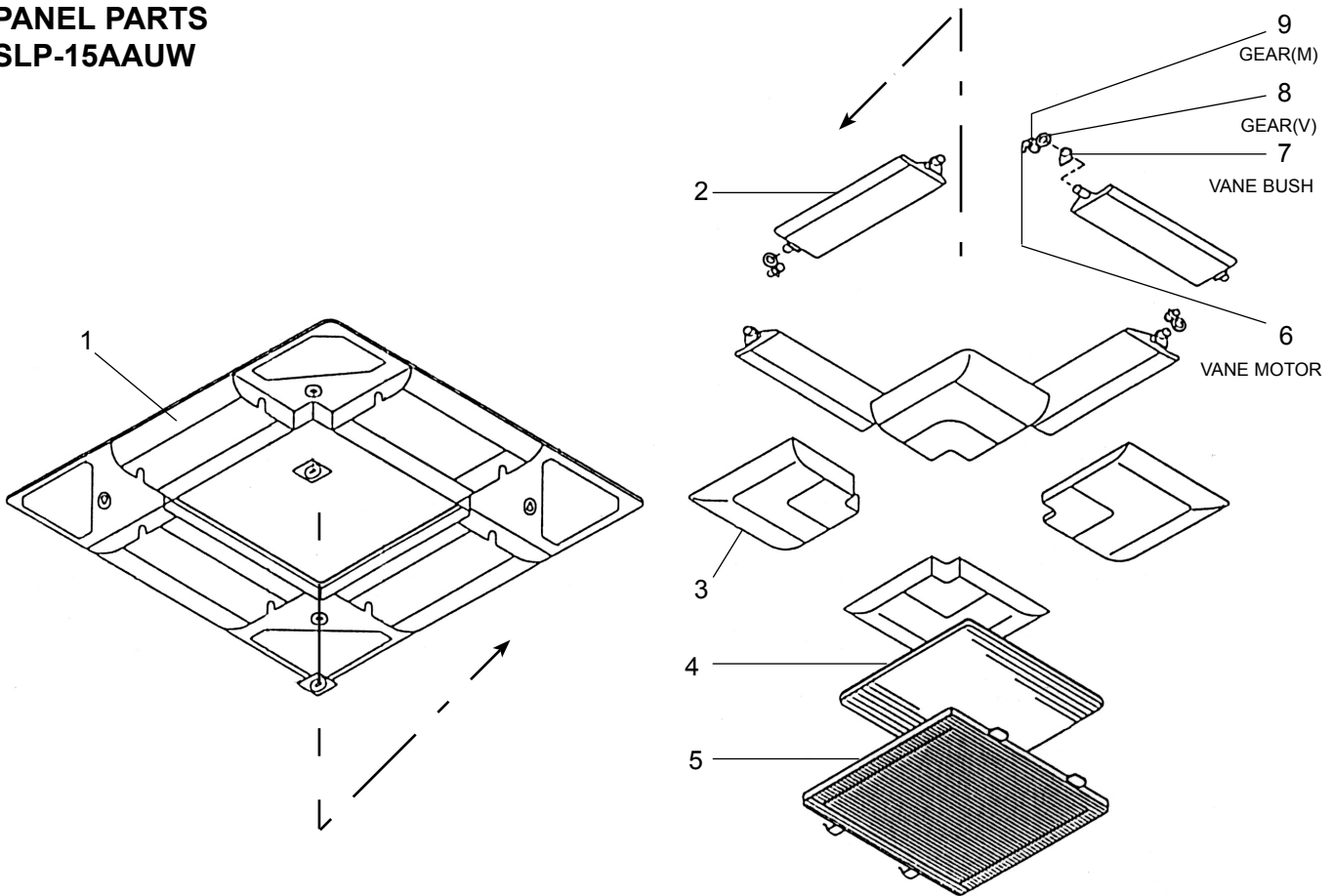

No.	RoHS	Parts No.	Parts name	Specification	Q'ty/set		Remarks (Drawing No.)	Wiring Diagram Symbol	Recom- mended Q'ty
					SLP-15	AAUW			
1	G	E17 425 003	AIR OUTLET GRILLE		1		including H2	H2	
2	G	E17 425 037	AUTO VANE		4				
3	G	E17 423 975	CORNER PANEL		4				
4	G	E17 103 100	AIR FILTER		1				
5	G	E17 423 010	INTAKE GRILLE		1				
6	G	E17 103 303	VANE MOTOR		4			MV	
7	G	E17 425 044	VANE BUSH		8				
8	G	E17 103 031	GEAR (V)		4				
9	G	E17 103 032	GEAR (M)		4				

ELECTRICAL PARTS
SLZ-KA09NA.TH

SLZ-KA12NA.TH

SLZ-KA15NA.TH

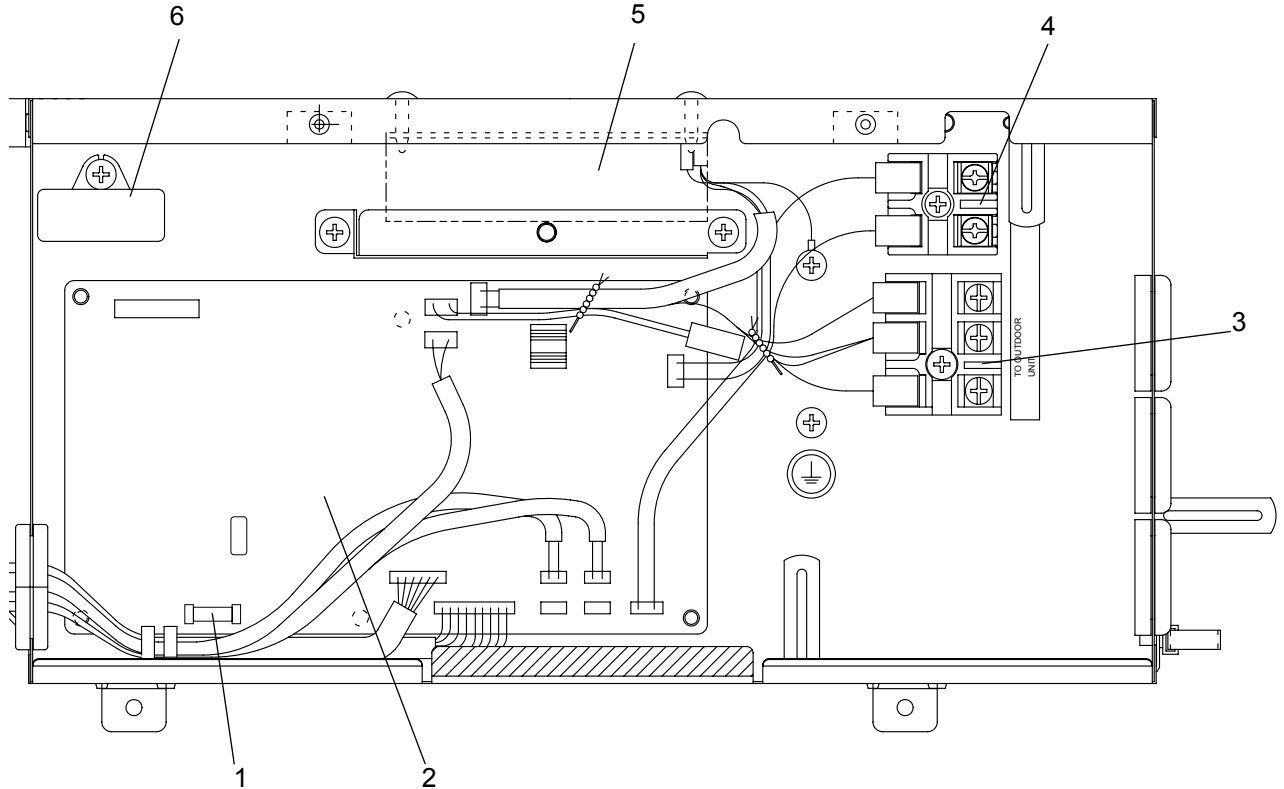

No.	ROHS	Parts No.	Parts name	Specification	Q'ty/set	Remarks (Drawing No.)	Wiring Diagram Symbol	Recom- mended Q'ty
					SLZ-KA09/12/15 NA.TH			
1	G	E17 250 382	FUSE	250V 6.3A	1		FUSE	
2	G	E17 608 447	INDOOR CONTROLLER BOARD		1		I.B	
3	G	E17 162 375	TERMINAL BLOCK	3P(S1,S2,S3)	1		TB4	
4	G	E17 156 375	TERMINAL BLOCK	2P(1,2)	1		TB15	
5	G	E17 154 440	INDOOR POWER BOARD		1		P.B	
6	G	E12 542 351	INDOOR FAN CAPACITOR	1.5 μ F/ 440VAC	1		C1	

FUNCTIONAL PARTS
SLZ-KA09NA.TH
SLZ-KA12NA.TH
SLZ-KA15NA.TH

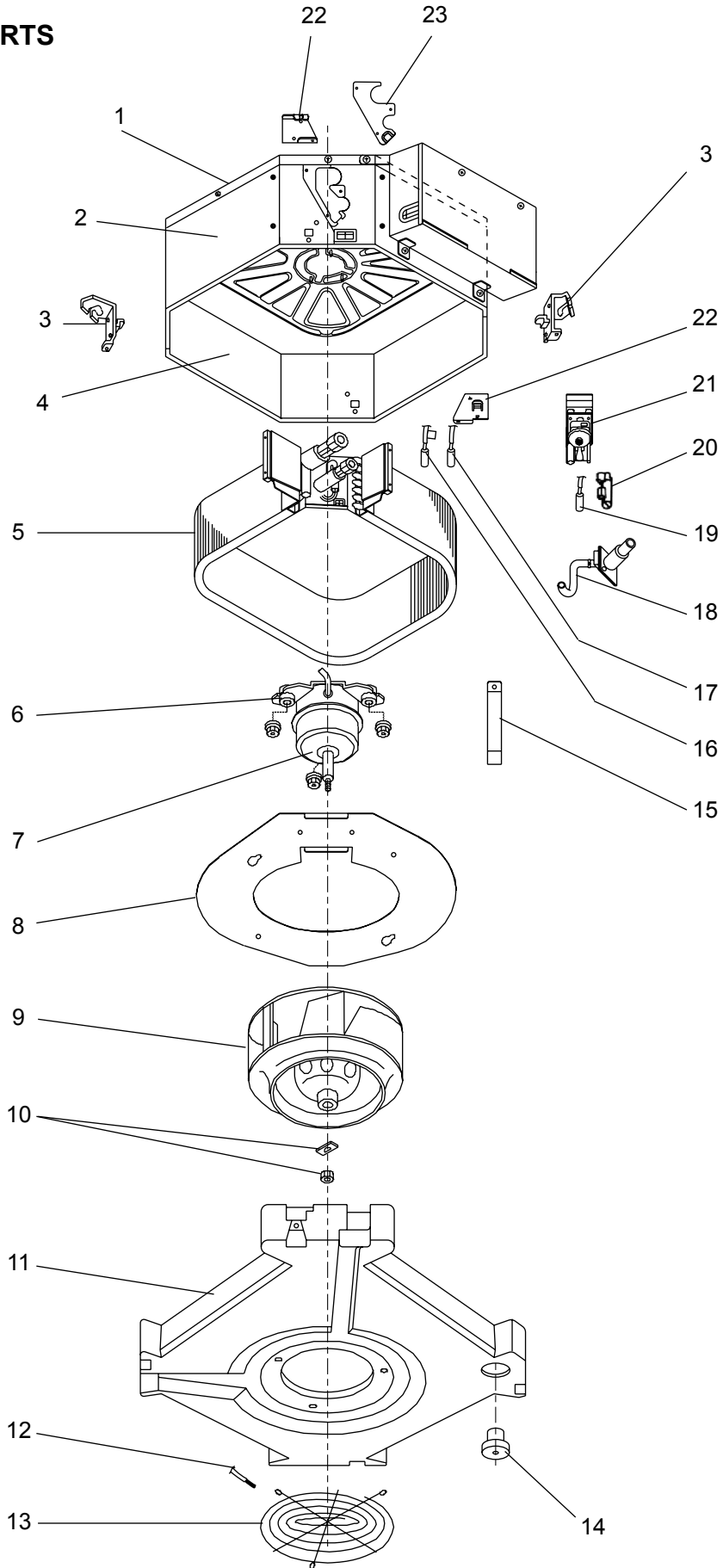



No.	RoHS	Parts No.			Parts name	Specification	Q'ty/set			Remarks (Drawing No.)	Wiring Diagram Symbol	Recom- mended Q'ty
							SLZ-KA					
							09	12	15			
							NA.TH					
1	G	E17	323	290	BASE		1	1	1			
2	G	E17	323	124	DRUM-1		1	1	1			
3	G	E17	323	808	LEG-1		2	2	2	1PCE/SET		
4	G	E17	324	124	DRUM-2		1	1	1			
5	G	E17	608	620	INDOOR HEAT EXCHANGER		1					
	G	E17	609	620	INDOOR HEAT EXCHANGER			1				
	G	E17	610	620	INDOOR HEAT EXCHANGER				1			
6	G	E17	104	105	MOTOR MOUNT		3	3	3	3PCS/SET		
7	G	E17	323	300	INDOOR FAN MOTOR	PK6N15-LA	1				MF	
	G	E17	324	300	INDOOR FAN MOTOR	PK6N20-LA		1			MF	
	G	E17	325	300	INDOOR FAN MOTOR	PK6N21-LA			1		MF	
8	G	E17	104	816	FLAT PLATE		1	1	1			
9	G	E17	104	502	TURBO FAN		1	1	1			
10	G	E17	104	097	SPL WASHER		1	1	1			
11	G	E17	323	700	DRAIN PAN		1	1	1			
12	G	E17	154	308	ROOM TEMPERATURE THERMISTOR		1	1	1		TH1	
13	G	E17	104	520	FAN GUARD		1	1	1			
14	G	E17	104	524	DRAIN PLUG		1	1	1			
15	G	E17	104	648	COIL SUPPORT		1	1	1			
16	G	E17	154	309	CONDENSER / EVAPORATOR TEMPERATURE THERMISTOR		1	1	1		TH5	
17	G	E17	154	307	PIPE TEMPERATURE THERMISTOR / LIQUID		1	1	1		TH2	
18	G	E17	323	702	DRAIN HOSE		1	1	1			
19	G	E17	104	266	DRAIN SENSOR		1	1	1		DS	
20	G	E17	104	241	SENSOR HOLDER		1	1	1			
21	G	E17	104	355	DRAIN PUMP		1	1	1		DP	
22	G	E17	323	809	LEG-2		2	2	2	1PCE/SET		
23	G	E17	323	006	COVER (DRUM)		1	1	1			





Mr. SLIM™

 **MITSUBISHI ELECTRIC CORPORATION**

HEAD OFFICE : TOKYO BLDG., 2-7-3, MARUNOUCHI, CHIYODA-KU, TOKYO 100-8310, JAPAN